



## PIXELS CONNECT PTE LTD



### ◆ SPECIFICATION

Model NO.	PIX-PCKSCAHTC500FEH	PIX-PCKSCAHTC500ESH
Video Output Mode	AHD/TVI: 5M@20fps/12.5fps, 4M@30fps, 2M@30fps; CVI: 4M@30fps, 2M@30fps	AHD/TVI: 5M@20fps/12.5fps, 4M@30fps, 2M@30fps; CVI: 4M@30fps, 2M@30fps
<b>Camera</b>		
Image Sensor	1/3" CMOS Sensor	1/2.8" SONY Starvis Back-illuminated CMOS sensor
Image Resolution	5M:2592*1944 4M:2560*1440 2M:1920*1080	5M:2592*1944 4M:2560*1440 2M:1920*1080
TV System	PAL/NTSC	PAL/NTSC
Electronic Shutter	Auto	Auto
Minimum Illumination	0.01Lux	0.005Lux
Scanning System	Progressive Scan	Progressive Scan
<b>Lens</b>		
Focus Length	Board Lens 3.6mm	Board Lens 3.6mm
Focus Control	Fixed	Fixed
Lens Type	Fixed	Fixed
<b>Night Vision</b>		
IR Cut Filter	YES	YES
Infrared LED	42μ x 2PCS	42μ x 2PCS
Infrared Distance	25M	25M
IR Status	AGC Auto Control	AGC Auto Control
<b>Camera Features</b>		
Starlight	/	YES
Day/Night	YES	YES

OSD Menu	YES	YES
WDR	DWDR	YES
UTC	YES	YES
Noise Reduction	DNR	AI-DNR
White Balance	AUTO / MANUAL	AUTO / MANUAL
Gain Control	AUTO	AUTO
<b>General</b>		
Housing	IP67	IP67
Bracket	NO	NO
Operation Temperature	-10°C ~ +60°C RH95% Max	-10°C ~ +60°C RH95% Max
Storage Temperature	-20°C ~ +60°C RH95% Max	-20°C ~ +60°C RH95% Max
Power Source	DC12V±10%,500mA	DC12V±10%,500mA
Dimension	96 x 96 x91	96 x 96 x91
Weight	600g	600g

Made In Taiwan

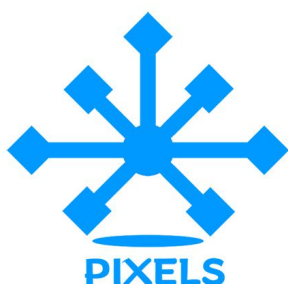
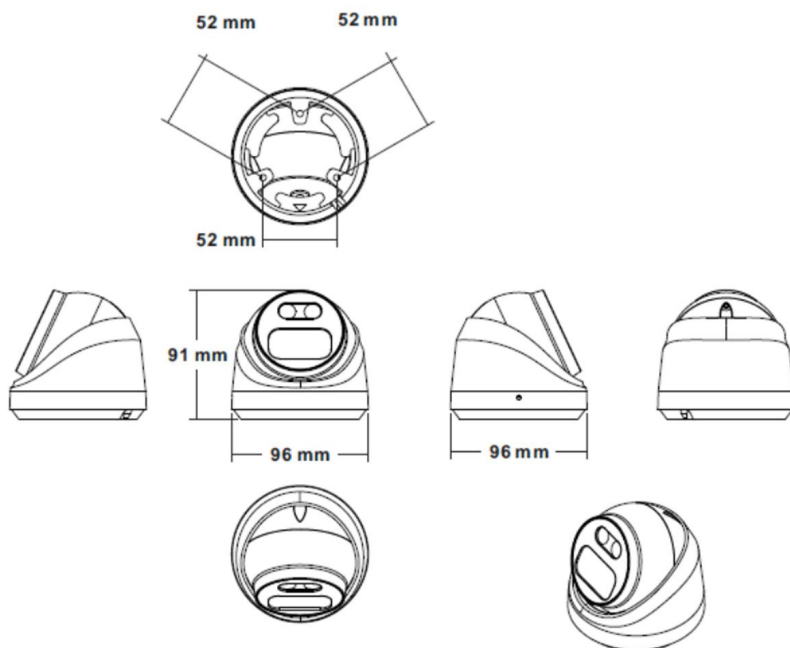

Analog Camera, IP Camera  
Dome & Bullet Cameras  
Hidden Cameras  
4K Cameras  
PTZ Cameras



Panoramic Camera  
4K Action Camera | Car Cameras  
Battery Cameras  
WiFi Door Bells  
Hidden Cameras



Fingerprint | Face | Card |  
Access PIN Reader  
Electromagnetic Lock  
Exit Button | Break Glass  
Video Door Intercom



**PIXELS CONNECT PTE LTD**

1013, Geylang East Ave 3, #01-144 Singapore 389728

pixelsconnect@gmail.com | www.pixelsconnect.com.sg | Tel:+65 6440 0023