



PIXELS CONNECT PTE LTD



◆ SPECIFICATION

Model NO.	PIX-PCKDDJHTC500FEH	PIX-PCKDDJHTC500ESH
Video Output Mode	AHD/TVI:5M@20fps/12.5fps, 4M@30fps, 2M@30fps; CVI: 4M@30fps, 2M@30fps	AHD/TVI: 5M@20fps/12.5fps, 4M@30fps, 2M@30fps; CVI: 4M@30fps, 2M@30fps
Camera		
Image Sensor	1/3" CMOS Sensor	1/2.8" SONY Starvis Back-illuminated CMOS sensor
Image Resolution	5M:2592*1944 4M:2560*1440 2M:1920*1080	5M:2592*1944 4M:2560*1440 2M:1920*1080
TV System	PAL/NTSC	PAL/NTSC
Electronic Shutter	AUTO	Auto
Minimum Illumination	0.01Lux	0.005Lux
Scanning System	Progressive Scan	Progressive Scan
Lens		
Focus Length	2.8-12mm	2.8-12mm
Focus Control	Manual	Manual
Lens Type	Manual	Manual
Night Vision		
IR Cut Filter	YES	YES
Infrared LED	42μ x 4PCS	42μ x 4PCS
Infrared Distance	30M	30M
IR Status	AGC Auto Control	AGC Auto Control
Camera Features		
Starlight	/	YES
Day/Night	YES	YES

OSD Menu	YES	YES
WDR	DWDR	YES
UTC	YES	YES
Noise Reduction	DNR	AI-DNR
White Balance	AUTO / MANUAL	AUTO / MANUAL
Gain Control	AUTO	AUTO
General		
Housing	IP67	IP67
Bracket	NO	NO
Operation Temperature	-10°C ~ +60°C RH95% Max	-10°C ~ +60°C RH95% Max
Storage Temperature	-20°C ~ +60°C RH95% Max	-20°C ~ +60°C RH95% Max
Power Source	DC12V±10%,750mA	DC12V±10%,750mA
Dimension	φ159 x 132(H)mm	φ159 x 132(H)mm
Weight	1.7Kgs	1.7Kgs

Made In Taiwan

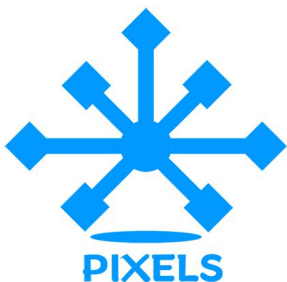
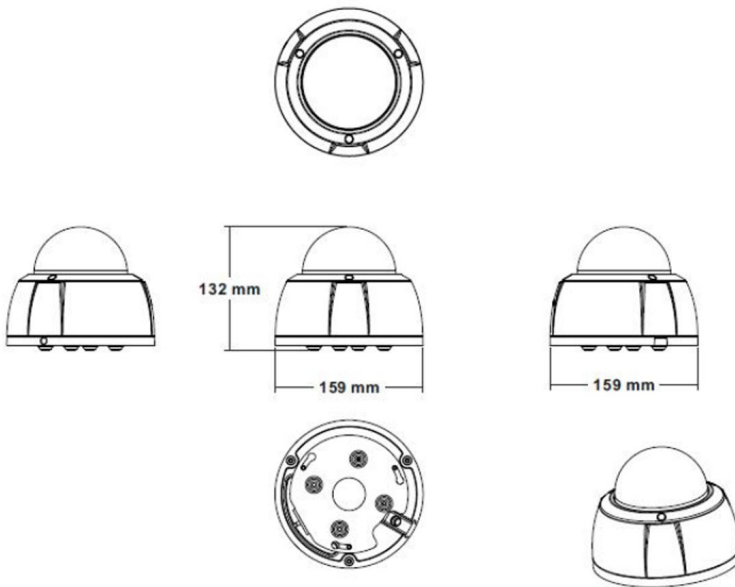

CCTV

Analog Camera, IP Camera
Dome & Bullet Cameras
Hidden Cameras
4K Cameras
PTZ Cameras



**Wireless
Cameras**

Panoramic Camera
4K Action Camera | Car Cameras
Battery Cameras
WiFi Door Bells
Hidden Cameras



**Biometric
Devices**

Fingerprint | Face | Card |
Access PIN Reader
Electromagnetic Lock
Exit Button | Break Glass
Video Door Intercom



PIXELS CONNECT PTE LTD

1013, Geylang East Ave 3, #01-144 Singapore 389728

pixelsconnect@gmail.com | www.pixelsconnect.com.sg | Tel:+65 6440 0023